



WARMING
S Y S T E M S

Electric Floor Warming Systems
Installation and Operation Instructions
Mat Heating Systems
Custom Fitted Heating Systems
Cable Set Heating Systems



Thank you for your purchase of a Warming Systems electric floor heating product.

The electric floor warming systems manufactured by Warming Systems Inc. are designed for interior floor applications, supplying 12 watts/square feet. They cannot be used for exterior snowmelt or ceiling heating applications. Install only below ceramic or porcelain tile, stone or brick floors, or in a self-leveling mortar base below vinyl floors or floating wood/laminate floors. Use only cement based mortars.

The electric heating systems are available in 110VAC and 220VAC and have three methods of installation: cable set, mat, and custom sized mat heating systems. One or more heating systems can be connected together by wiring them in Parallel. Pay close attention not to exceed the amperage capacity of the wiring, thermostat control or the Ground Fault Circuit Interrupter (GFCI).

Every electric floor heating system must have a Ground Fault Circuit Interrupter (GFCI) in the electrical circuit to prevent the possibility of electrical shock.

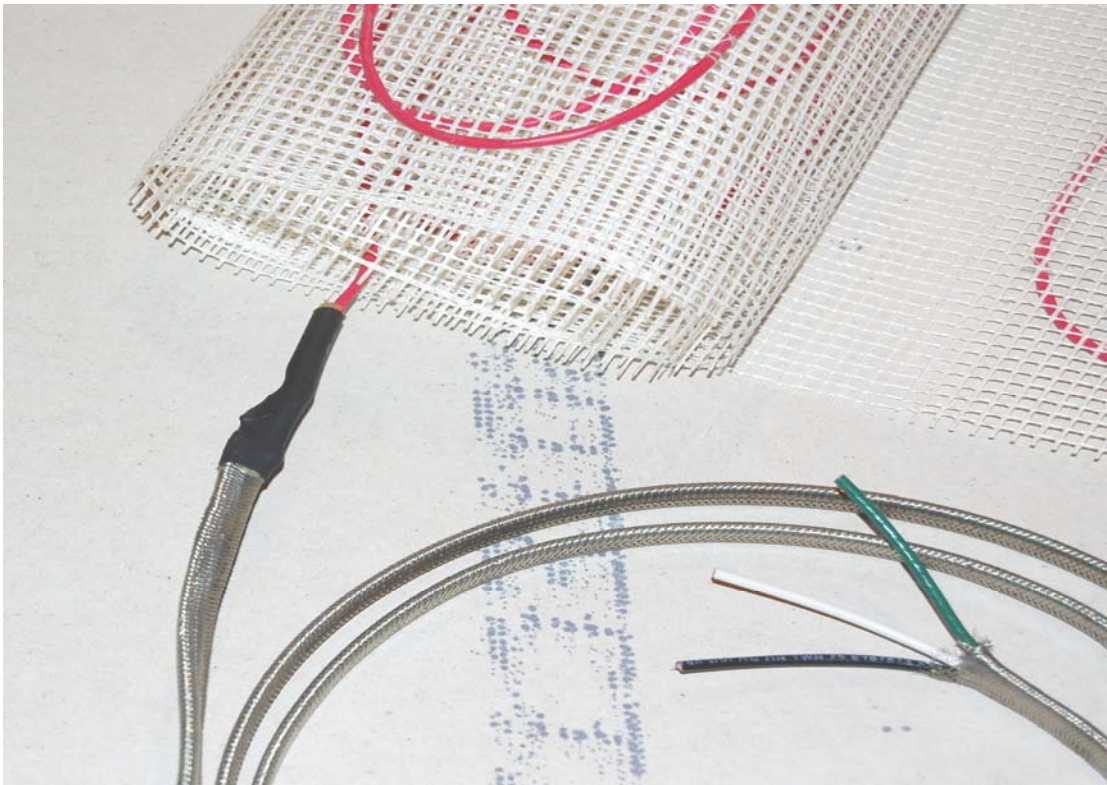



INSTALLATION CAUTIONS:

- NEVER: cut the red heating element
- NEVER: bang a trowel on the heating element
- NEVER: overlap heating elements, it may cause the overheating
- NEVER: install heating elements in adhesives or glues intended for vinyl tile or other laminate flooring. It must be embedded in cement based mortar
- NEVER: install mats under cabinets or other permanent objects such as cabinets
- NEVER: install under carpet, wood, vinyl, or other non-masonry flooring without thin-set, thick-set, or self-leveling mortar
- NEVER: Remove the nameplate label at the end of the mat

- ALWAYS: pay attention to voltage and amperage requirements
- ALWAYS: continue to confirm the ohm resistance across the heating system remains the same before, throughout, and after the installation
- ALWAYS: make sure all electrical work is done by qualified persons in accordance with local building and electrical codes, and the National Electrical Code (NEC), especially Article 424, Part IX of the NEC, ANSI/NFPA 70 and Section 62 of CEC Part I.

Part A: Test the floor heating system:

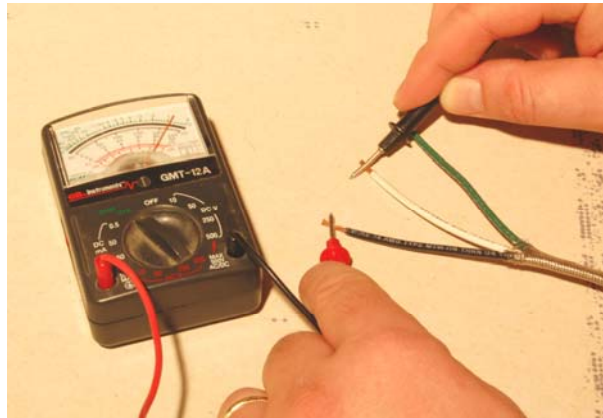

Confirm the Ohm resistance between the Black and White cold lead wires are within 10% of the resistance rating on the systems label.

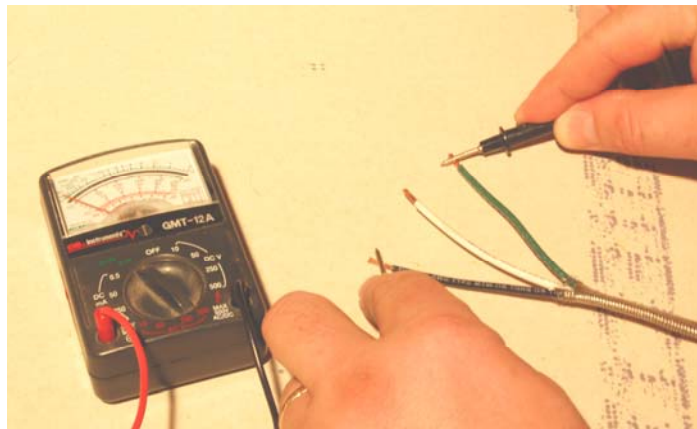

Confirm there is no short to ground on in the system by measuring the resistance between the Green ground wire and the Black/White cold leads. The reading on the ohm meter should be “open” or “infinite” resistance.



Part B: Thermostat and Electrical Requirements:

Only a certified electrician who is familiar with electrical installation codes and practices can connect the floor heating mat. All wiring must comply with the specifications in the US National Electric Code and all local electrical regulations and standards.

Thermostat: Use a floor sensing thermostat with built in GFCI to directly control the floors temperature where the mat is installed. The Ground Fault Protection (GFCI) will guard against electrical hazards in case the mat is damaged.

The thermostat should be located on an interior wall 60" from the floor, mounted in a 4" square electrical box with a single gang mud ring, and located within reach of the mats 10' cold lead.

For up to three mats, install a 3/4" conduit from the electrical box down to the floor for installation of the mats power cold leads. Drill a hole on the top and side of the bottom plate for routing of the cold leads/sensor probe into the conduit.





Electrical Requirements:

Verify that the electrical circuit powering the heating system has adequate amperage capacity available.

Amperage Draw Requirements:

- 10 square feet requires 1 Amp @ 110 volt.
- 20 square feet require 1 Amp @ 220 volt.

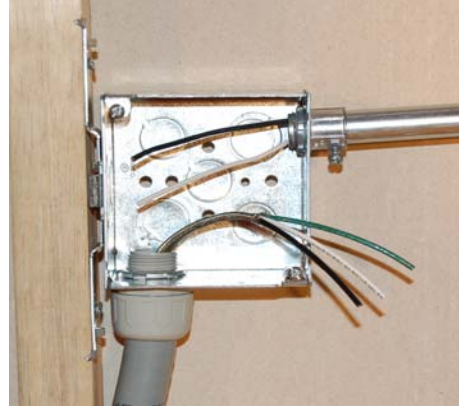

Example: 50 sqft requires 5 amps @ 120 volts.

Part C: Determine where to heat:

Calculate the area to be heated by measuring the square footage making sure not to include permanent objects such as cabinets, fixtures, toilets, sinks, tubs, center islands, etc.

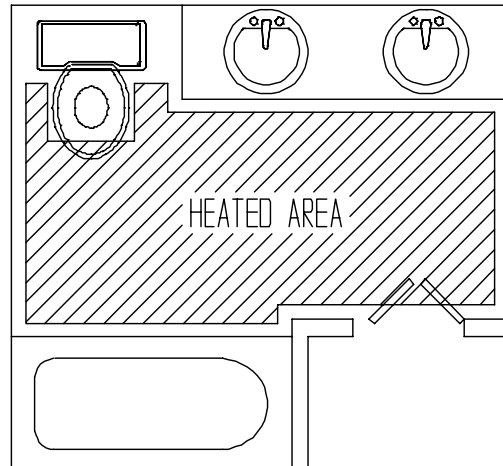



Part D: Installation:

Floor Preparation: Make sure the floor is thoroughly cleaned and free from anything that may damage the heating element.

MAT INSTALLATION

Fitting Mat: Unroll the floor heating mat making sure the power leads reach the electrical box. Manipulate the mat to fit the desired heating area by using the turning techniques as described below. NEVER CUT THE RED HEATING ELEMENT. The mat will heat up to 2" from the red heating element.

Mat Turn Techniques

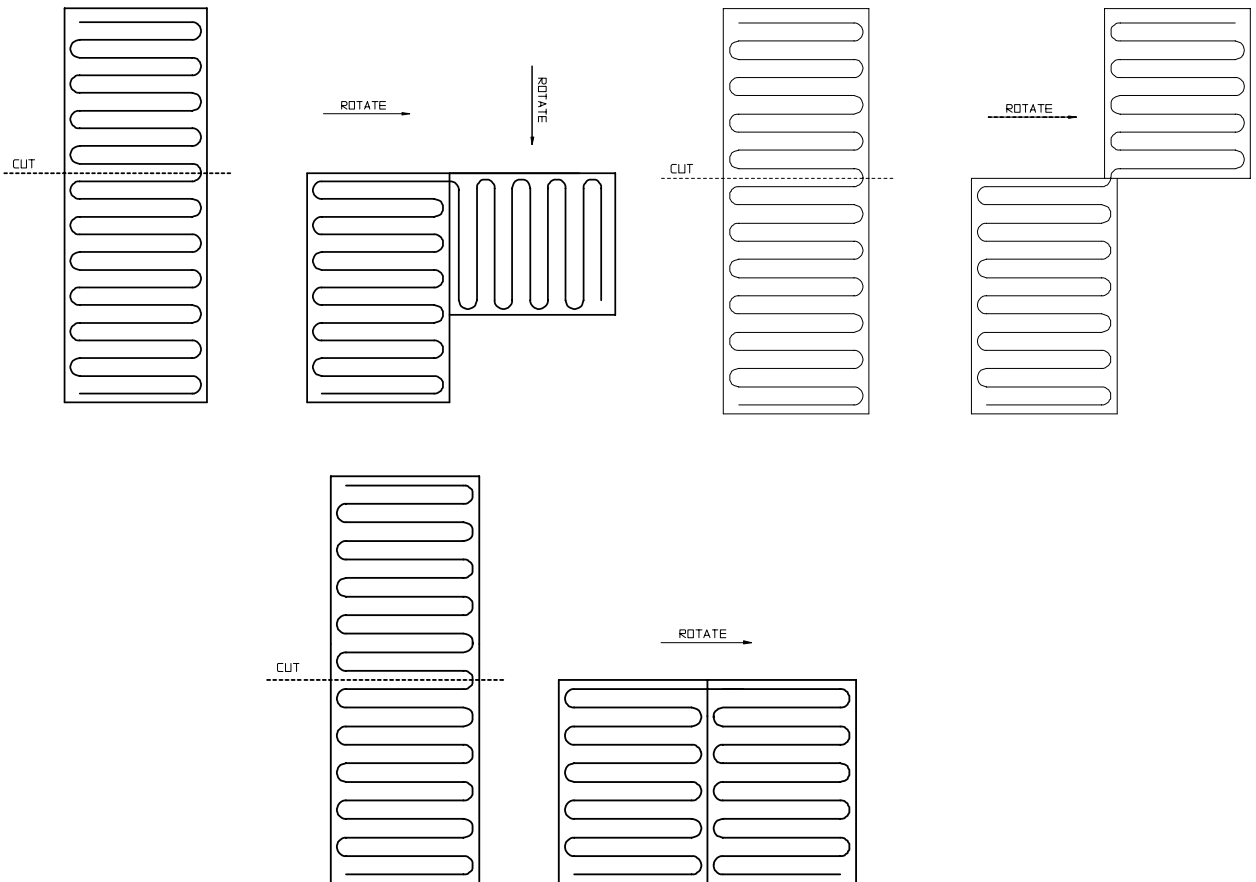



CABLE SET INSTALLATION

Laying Cable Set: It is important to properly de-coil the heating cable to prevent twisting. Insert a rod through the cable spool hub to allow spool to spin freely.

Pull the cold lead from the spool and feed it through the conduit pipe to the electrical control box. The cable should be pulled until the factory splice on the floor is within about 12” of the entry to the conduit.

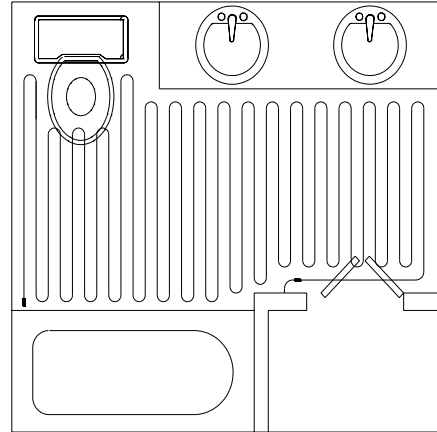

Run the “red” heating element 3” apart throughout the area to be heated using aluminum tape to secure the cable to the floor. The cable spacing can be adjusted in low traffic areas to compensate for excess cable.

- NEVER CUT THE RED HEATING ELEMENT
- NEVER OVERLAP THE HEATING ELEMENT OR COLD LEADS

CUSTOM FITTED MAT INSTALLATION

Fitted Mat: Unroll mat in designated area. Ensure that the red heating wire is not closer than 2” to permanent objects including walls, vanities, showers, etc.



Part E: Thermostat Sensor Wire and Power Leads

Power Leads: Feed the cold lead up the conduit to the electrical control box. Mark on the floor where the factory splice will be located. Because this splice is thicker than the rest of the cold lead, it may be required to “notch” the floor with a chisel to accommodate this extra thickness.

Thermostat Sensor: Run the thermostat sensor up the conduit to the electrical control box. The temperature sensor should be located in-between two heating elements, at least 6” from the edge for the heated area.

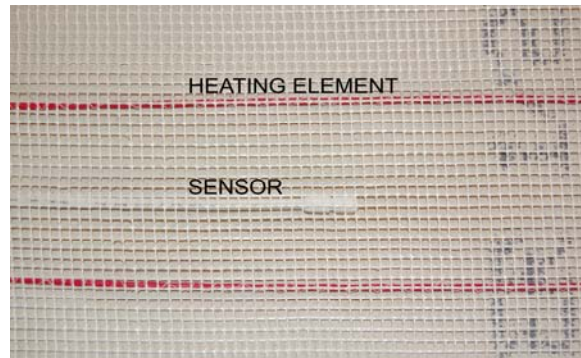

Part F: Tile Installation: If installing tile or stone floor coverings, apply thin-set cement-based mortar over the heating system using the trowel. Use the flat side and smooth over the heating elements.

Proceed to install tiles per tile manufacturer instructions.



Part G: Final Wiring:

All electrical work should be done by a qualified person, according to all national and local building and electrical codes.

Connecting the LINE wires: Connect the black “line” wire on the thermostat to the black wire of the incoming power. Connect the white “line” wire on the thermostat to the white wire of the incoming power.

Connecting the LOAD wires: Connect the black “load” wire on the thermostat to the black wire(s) coming from the floor heating system. Connect the white “white” wire on the thermostat to the white wire(s) coming from the floor heating system.

Connecting the green GROUND wire: The green wire from the floor heating system should be connected to the bare or green ground wire from the incoming power. If using a metal electrical box and metal conduit, attached the green ground wire to the electrical box.

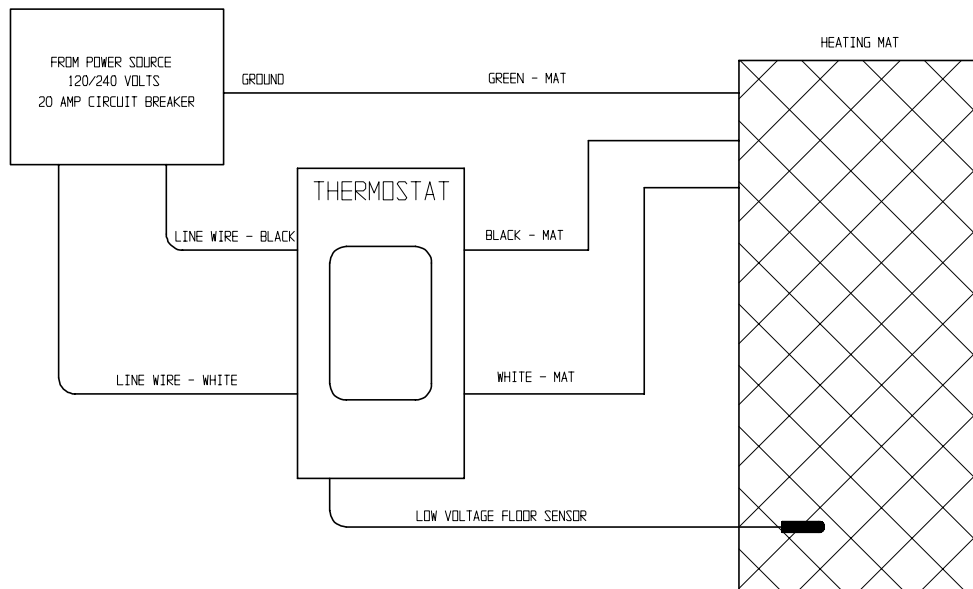

Part H: Start-up: After all of the controls are terminated, do not energize the system until the cement materials are fully cured. This may take weeks. Refer to mortar manufacturers instructions for actual curing time.



OPERATING TIPS

- When first energized, the Warming System may take up to 3 hours to fully warm your floor
- Energy consumption will vary depending on user preferences, warmer floors require more energy, but typically will be about 70% of installed capacity when the system is energized.
- Energy consumption can be minimized by turning the system off when the floor heat is not required.
- Avoid placing thick mats or rugs on the heated floor surface, especially in the area where the floor temperature sensor is located.
- Avoid placing furniture over heated areas.

*WARMING SYSTEMS INC.
PO BOX 543
SPRING GROVE, IL 60081*